



Nando 502 Wash is an incredibly compact luminaire for stage lighting, specially designed for mixed use, both indoors and outdoors, and in salty environments.

Nando 502 Wash can achieve a luminous flux of 11,000 lumens and offer a perfectly homogeneous mix of pastel or saturated colours.

★ KEY FEATURES

➤ Upgraded glass lightguide

In Nando 502 wash, new CNC light guides ensure a uniform beam by homogenizing 12 high-performance 40 W LEDs in four colours (RGB and Lime) into a single cohesive light, essential for best-quality stage lighting.

➤ Broad spectrum coverage with Lime

We chose the RGB-Lime colour mixing system for our Nando wash light series to overcome the limitations of traditional RGB fixtures:

- **Spectrum Gaps in RGB and RGB-W Systems:** Traditional RGB/W fixtures leave gaps in the spectrum, resulting in less vibrant and imbalanced colours.
- **Broad-Spectrum Coverage with Lime:** Lime fills these gaps, harmonizing with red, green, and blue to create even colour distribution, from subtle pastels to bold, saturated hues, and achieving natural, rich lighting effects.
- **Optimal Mixing:** Lime at full brightness unlocks the full range of colours, delivering the richest and most vibrant tones.

➤ As lightweight as it is efficient

Nando 502's zoom lens is made from lightweight PMMA. By refining the design, we've made the lens thinner and 50% lighter than before. This reduces the fixture's front weight, minimizing the need for counterweights and ensuring a lightweight IP65 design at just 15.6kg.

➤ Quiet cooling

Nando 502 uses the same advanced liquid cooling system as Rivale and Veloce, reflecting over 15 years of heatpipe technology expertise. Key features include:

- **Fins and Cooling Pipes:** Efficiently pull heat away from the LED module to maintain optimal temperatures.
- **Two Large Fans:** Direct cool air onto the fins and pipes for enhanced cooling.
- **Aluminum Covers:** Absorb and disperse internal heat effectively, ensuring efficient and quiet operation.

TECHNICAL SPECIFICATIONS

SOURCE	
Engine	RGB-L High-Power LED
LED Watts	40 W
LED Engine Life (L70)	Up to 40,000 hours
LED Refresh Rate	1.2 kHz, 2.4 kHz, 16 kHz, 25 kHz
Dimming	Electronic
Dimming Curves	Square & Linear
Dimming Control Options	Auto on/off dimmer smoothing when Snap effects
Strobe Speed	1-25 Hz Per Second
Strobe Modes	Strobe Effects / Pulse Effects / Random Effects

ELECTRICAL	
Max Power Consumption	550 W
Standby Consumption	65 W @ 20 °C
Voltage Range	100-240 V 50-60 Hz
Current (Max)	2.4 A @ 230 V / 5 A @ 110 V
Inrush (Half Cycle)	110 V: 12.6 A 230 V: 10.5 A
Maximum Current available at the output	16 A
Connector	True1 In/Thru
Power Supply Unit	Active PFC
Contains Battery	N/A

TYPICAL POWER AND CURRENT	
120V , 60Hz	4.18 A, 501.7 W, PF 0,993
208V, 60Hz	2.38 A, 495 W,PF 0.978
230V, 50Hz	2.13 A, 490.8 W, PF 0.970
240V, 50Hz	2.11 A, 506.4 W, PF 0.970

Suitable disclaimer nominal, etc

OPTICAL PERFORMANCE	
Lens Size	210 mm (8.27 in)
Zoom Range	3.5° to 53°
Zoom Ratio	15:1
Gate Size	N/A

MOVEMENT		
Pan Range		540°
Pan Speed (End to End or range)	180°	98.5 rpm
	360°	143.2 rpm
	EtoE	195.4 rpm
Tilt Range		270°
Tilt Speed (End to End or range)	180°	84.2 rpm
	EtoE	106.5 rpm
Resolution		8- or 16-bit
Calibration Time		42 sec
Position Correction System		Yes / Automatic repositioning
Follow Spot Modes		Tracking system

COLOUR SYSTEM	
Colour System(s)	RGB-L with 4.29 billions colours
Control	RGB-L 8-bit
CTO	Virtual Wheel
Variable CTP	2500 to 8000 K
Colour Wheel	Virtual colour wheel, including most usuals white colour temperature presets
Colour Wheel Effects	N/A

GOBOS	
Indexing Wheel	N/A
Indexing Gobos	N/A
Gobo Diameter (Index)	N/A
Image Diameter (Index)	N/A
Static Wheel	N/A
Static Gobos	N/A
Gobo Diameter (Fix)	N/A
Image Diameter (Fix)	N/A
Gobo Thickness	N/A
Animation Wheel	N/A
Animation Details	N/A

TECHNICAL SPECIFICATIONS

PERFORMANCE		
LED board out (Sphere)		15,000 lm
Fixture Output (Sphere)		10,012 lm (Fan Mode Auto)
		10,842 lm (Fan Mode Stage)
		8,182 lm (Fan Mode Silence)
		5,209 lm (Fan Mode Super Silence)
Fixture Output (Goniometer) balanced white		7,910 lm
Field Lumens (Goniometer)	Narrow	4,895 lm
	Middle	N/A
	Wide	8,848 lm
Lumen Per Watt (LPW) Max fixture output / 230 V Typical power		18
CCT balanced white		6,500 K
Δ uv balanced white		0.0047
CRI balanced white		Ra: 77 (±2)
With TrueColour Enhancer™ Filter		> 86
Tm30 balanced white		Rf: 82,8 Rg: 112,3
TLCI balanced white		66
CQS balanced white		86.8

IMAGING	
Framing	N/A
Framing Rotation	N/A
Iris	N/A
Frost	N/A
Effect	<ul style="list-style-type: none"> ▪ 2D & 3D graphical effects capabilities ▪ Effects can be coupled with beam, wash or matrix applications ▪ Built-in pattern effects with speed and fade controls for scenic applications ▪ Individual control of each pixels

CONNECTORS	
Power	In/Thru powerCON True 1
DMX	In/Thru 5 Pin XLR
Network	In/Thru RJ45
Wireless	DMX Only

CONTROL	
DMX Control	DMX (USITT DMX-512-A) RDM (ANSI/ESTA E1.20)
Transceiver/Receiver	RS-485 with Opto Isolation
DMX Modes	4+3 User modes
Channel Count	26/37/46/86 Modes
DMX Chart	Scan the QR code on page 5
Network Protocols	ArtNet & sACN
Local Control	Colour LCD Panel 5 Menu Buttons NFC
Stand Alone Mode	Leader/Follower, presets 250
RDM Functions	Yes
Wireless DMX	CRMX TiMo RDM receiver
E-Sim Ready	Optional
USB Port	No

THERMAL	
Max Surface Temperature, steady state, at Ta 40°	85 °C (185 °F)
Max Ambient Temperature (Ta Max)	45 °C (113 °F)
Min Ambient Temperature (Ta Min)	-20 °C (-4 °F)
Total Heat Dissipation (Calculated +/- 10%)	156 BTU p/h 490 W @ 230 V
Minimum distance to illuminated surface	1 m (3.28 ft)
Minimum distance to combustible surface	3 m (9.84 ft)
Thermal Protection system	Yes
Cooling modes	See Acoustics
Cooling System	Advanced Liquid Cooling

TECHNICAL SPECIFICATIONS

ACOUSTICS STATIC		
Fan Mode	dB ^{A1}	NC ²
Auto	35.7	28
Stage	40	33
Silence/Studio	28.6	19
Super Silence	21.9	N/A

DYNAMIC		
Mode	dB ^{A1}	NC ²
Auto	44.3	30
Stage	44.9	34
Silence/Studio	44.5	31
Super Silence	37.7	23

1. Measured @ 1m Static, 10 dBA ambient
 2. Noise Criterion
https://www.engineeringtoolbox.com/nc-noise-criterion-d_517.html

ENVIRONMENTAL	
IP Rating	IP 65
Salt Spray Testing	Pending
Estimated embodied carbon including: <ul style="list-style-type: none"> A1 - Raw materials of fixture and packaging A3 - Product manufacturing 	149.4 kg CO ₂ e/fixture
Recycling options	Packaging widely recyclable. Cardboard is made of recycled pulp ³ .
SIP Optional	Yes

Our Environmental Commitment

3. Up to 92%

WARRANTY	
Fixture	2 years
LED Engine	2 years

From date of invoice

INSTALLATION	
Orientation	Any
Mounting attachments	<ul style="list-style-type: none"> Fastening brackets system: two Omega 1/4 turn brackets designed for use with standard clamps Mounting points: four 1/4 turn locking fittings allowing installation of Omega brackets on luminaire Safety cable attachment point
Installation version	Yes IP66

CONSTRUCTION	
Colour	Carbon Black Standard Custom colours on request
Materials	<ul style="list-style-type: none"> Moving-head skeleton made of aluminium and steel metal plates Head in die-cast aluminium Base in die-cast aluminium Heatsinks in aluminium Arms and head in self-extinguishing fire retardant ABS PC (VO class) Two-side handles for transportation Four heavy-duty feet for better stability

INCLUDED ITEMS	
Manual	1
OMEGA brackets with quarter-turn locks	2
Cables	<ul style="list-style-type: none"> IP65: 1 cable PowerCON True1 TOP to bare end, 1.5m IP66: DMX IN / OUT tails to bare end for IP66 DMX connection <ul style="list-style-type: none"> Ethernet IN / OUT tails to bare end for IP66 ArtNet™ connection Power tail to bare end for IP66 power connection
Other accessories	N/A

TECHNICAL SPECIFICATIONS

PHYSICAL	
Fixture	
Length	342 mm (13.5 in)
Height	467 mm (18.4 in)
Depth	268 mm (10.5 in)
Weight	15.6 kg (30.4 lb)
Shipping Dimensions (without foam)	
Length	460 mm (18.1 in)
Height	580 mm (22.8 in)
Depth	385 mm (15.2 in)
Weight	23.1 kg (50.9 lb)
Shipping Dimensions (with foam)	
Length	400 mm (15.7 in)
Height	565 mm (22.2 in)
Depth	340 mm (13.4 in)
Weight	23.1 kg (50.9 lb)
In SIP Dimensions	
Length	395 mm (15.55 in)
Height	480 mm (18.9 in)
Depth	335 mm (13.2 in)
Weight (excl fixture)	8 kg (17.6 lb)

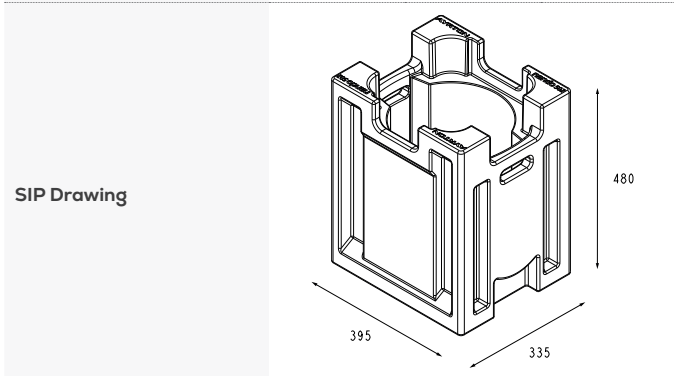

SUPPORTING DOCUMENTS	
Manual	
GDTF Profile	
GMA Profile	
IES FILE	
DMX Chart	
Photometric Files	
Software	
Warranty	

COMPLIANCE	
EU (EMC & LVD)	<ul style="list-style-type: none"> EMC Directive 2014/30/EU LVD Directive 2014/35/EU
US (Safety & EMC)	<ul style="list-style-type: none"> UL 1573 FCC Part 15, Subpart B: 2021
Substance Regulations	<ul style="list-style-type: none"> RoHS REACH CP65
Declarations	Scan the QR code above

ORDERING DETAILS	
Nando 502 Wash	013420

ACCESORIES	
IP Test Kit	048250
Lynx Control	045130

TECHNICAL SPECIFICATIONS

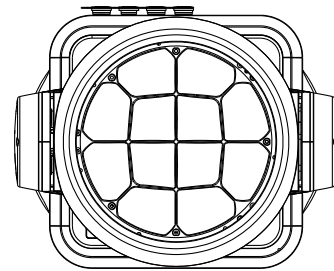
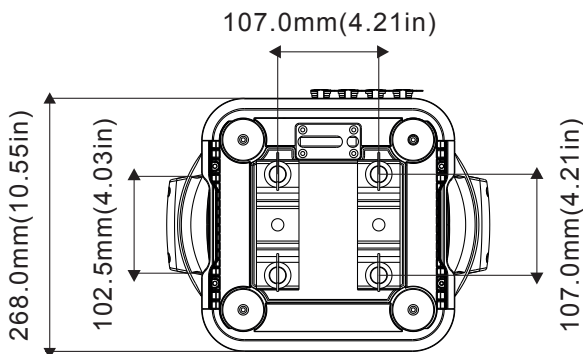
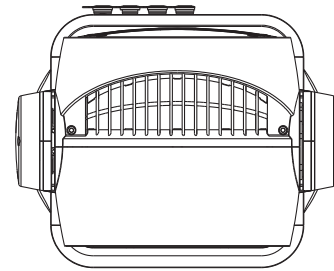
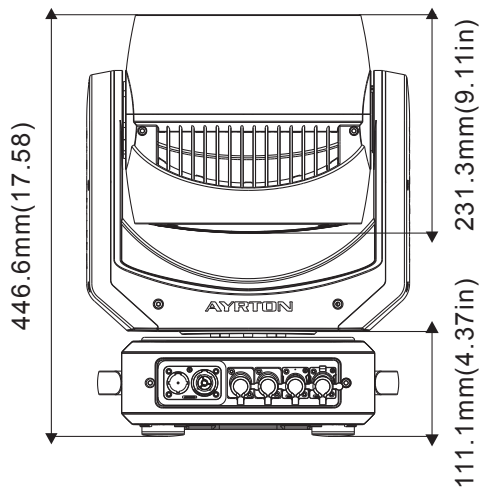
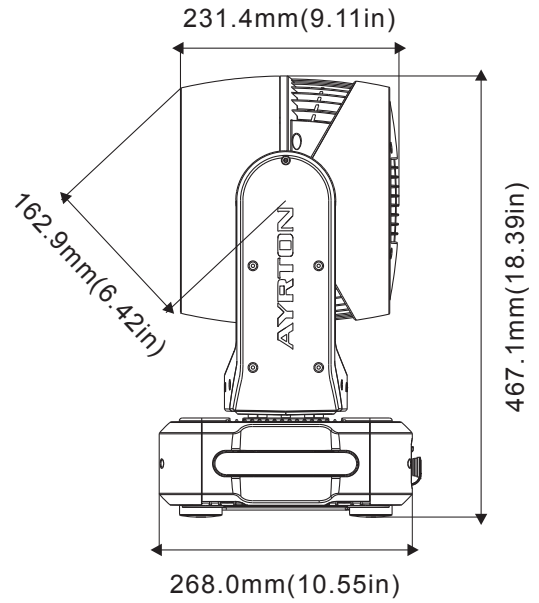
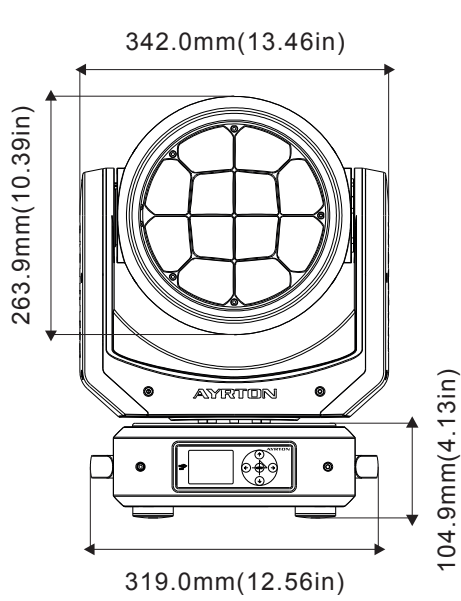

AUTO MODE: PHOTOMETRIC DETAIL

MIN ZOOM

BEAM OPENING

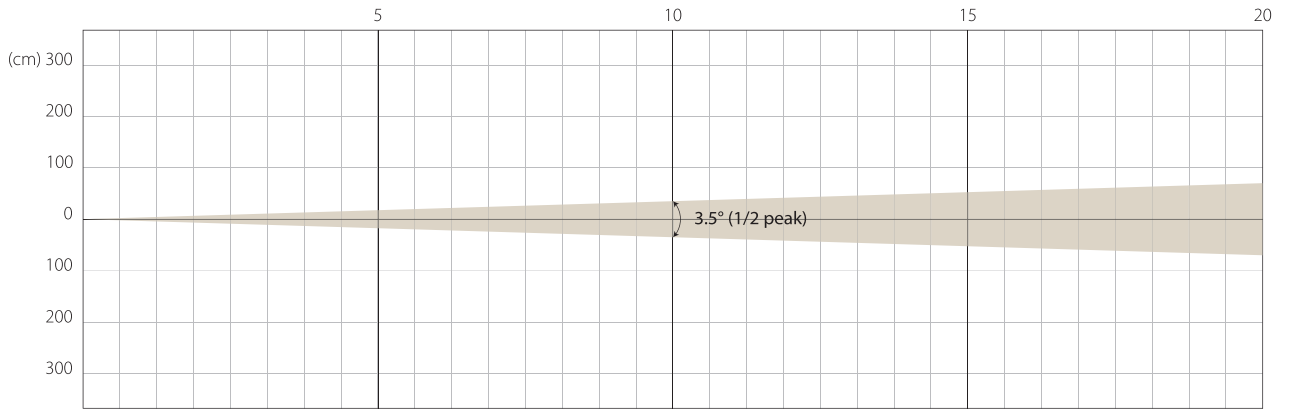

INTENSITY

Distance (m)	5		10		15		20	
	lux	diameter	lux	diameter	lux	diameter	lux	diameter
Red	8359	0.35	2090	0.7	929	1.05	522	1.4
Green	19583	"	4896	"	2176	"	1224	"
Blue	4231	"	1058	"	470	"	264	"
Lime	23909	"	5977	"	2656	"	1494	"
RGB-L	47979	"	11994	"	5331	"	2999	"

MAX ZOOM

BEAM OPENING

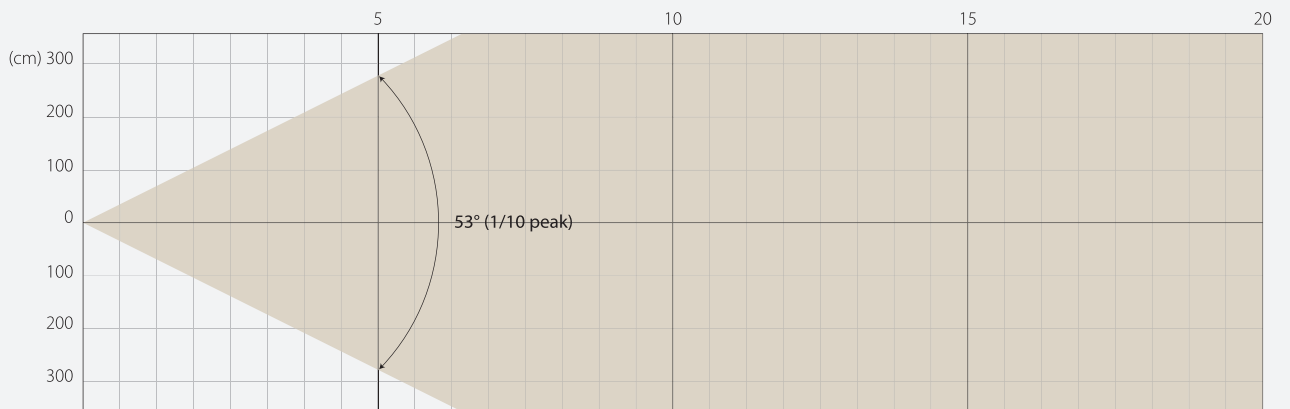

INTENSITY

Distance (m)	5		10		15		20	
	lux	diameter	lux	diameter	lux	diameter	lux	diameter
Red	187	5.54	46	11.09	21	16.63	12	22.17
Green	385	"	96	"	43	"	24	"
Blue	84	"	21	"	9	"	5	"
Lime	471	"	117	"	52	"	29	"
RGB-L	958	"	239	"	107	"	60	"

STAGE MODE: PHOTOMETRIC DETAIL

MIN ZOOM

BEAM OPENING

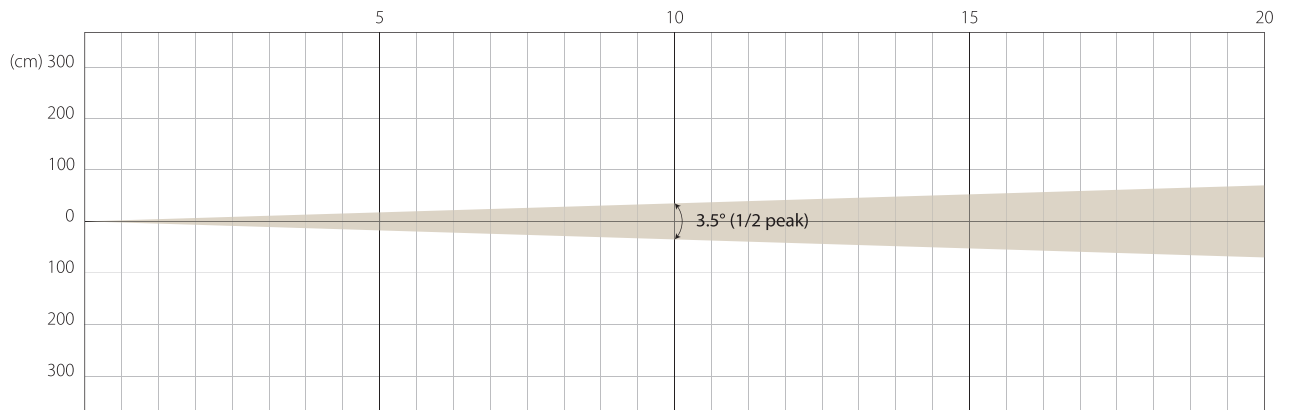

INTENSITY

Distance (m)	5		10		15		20	
	lux	diameter	lux	diameter	lux	diameter	lux	diameter
Red	8777	0.35	2195	0.7	975	1.05	548	1.4
Green	20562	"	5141	"	2285	"	1285	"
Blue	4443	"	1111	"	494	"	277	"
Lime	25104	"	6276	"	2789	"	1569	"
RGB-L	50378	"	12594	"	5598	"	3149	"

MAX ZOOM

BEAM OPENING

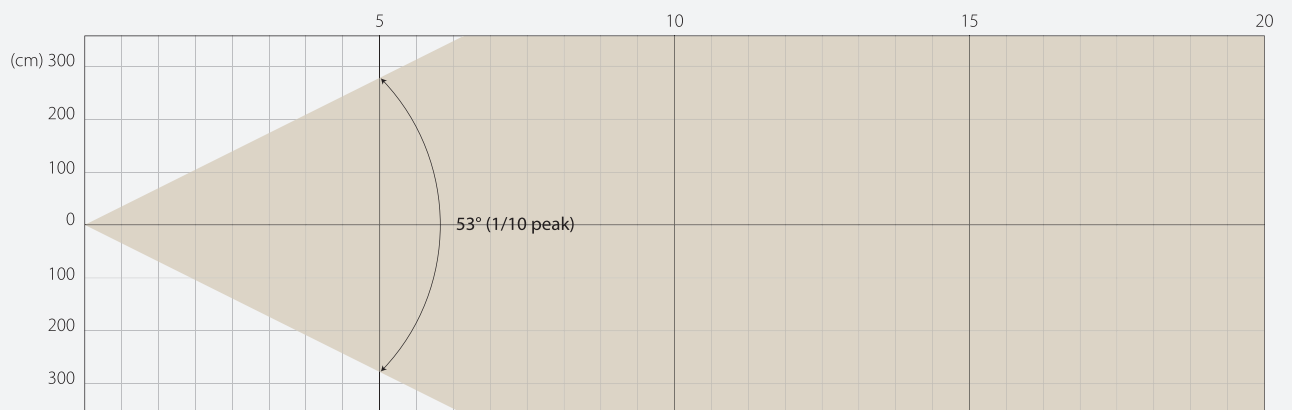

INTENSITY

Distance (m)	5		10		15		20	
	lux	diameter	lux	diameter	lux	diameter	lux	diameter
Red	196	5.54	48	11.09	22	16.63	13	22.17
Green	404	"	101	"	45	"	25	"
Blue	88	"	22	"	9	"	5	"
Lime	495	"	123	"	55	"	30	"
RGB-L	1006	"	251	"	112	"	63	"

SILENCE MODE: PHOTOMETRIC DETAIL

MIN ZOOM

BEAM OPENING

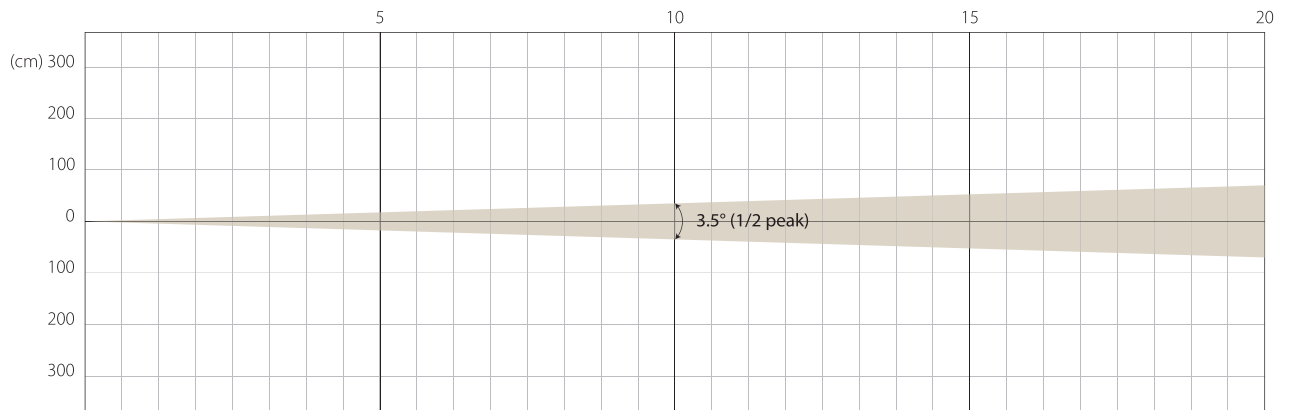

INTENSITY

Distance (m)	5		10		15		20	
	lux	diameter	lux	diameter	lux	diameter	lux	diameter
Red	6353	0.35	1588	0.7	706	1.05	397	1.4
Green	14883	"	3721	"	1654	"	930	"
Blue	3216	"	804	"	357	"	201	"
Lime	18171	"	4543	"	2019	"	1135	"
RGB-L	36464	"	9115	"	4052	"	2279	"

MAX ZOOM

BEAM OPENING

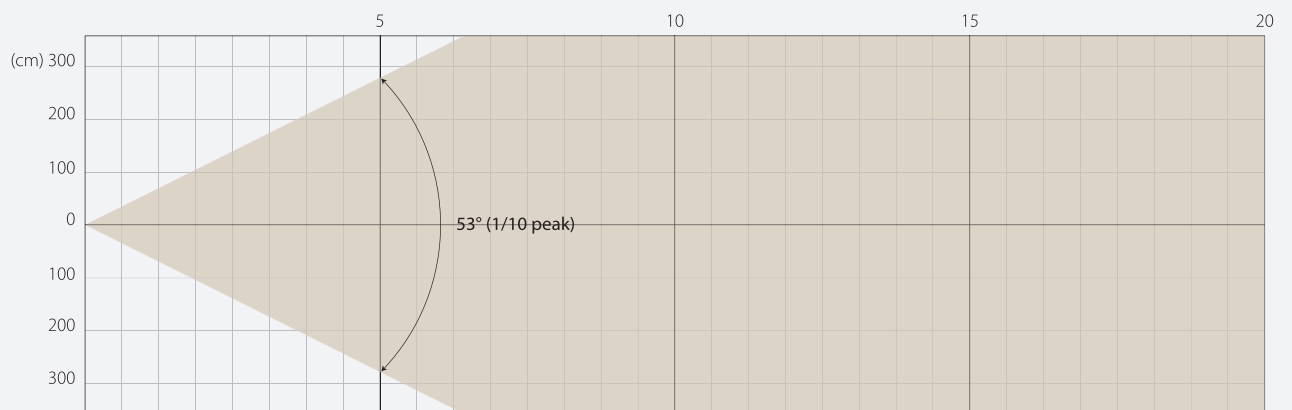

INTENSITY

Distance (m)	5		10		15		20	
	lux	diameter	lux	diameter	lux	diameter	lux	diameter
Red	142	5.54	35	11.09	16	16.63	9	22.17
Green	293	"	73	"	33	"	18	"
Blue	64	"	16	"	7	"	4	"
Lime	358	"	89	"	40	"	22	"
RGB-L	728	"	182	"	81	"	46	"

SUPER SILENCE MODE: PHOTOMETRIC DETAIL

MIN ZOOM

BEAM OPENING

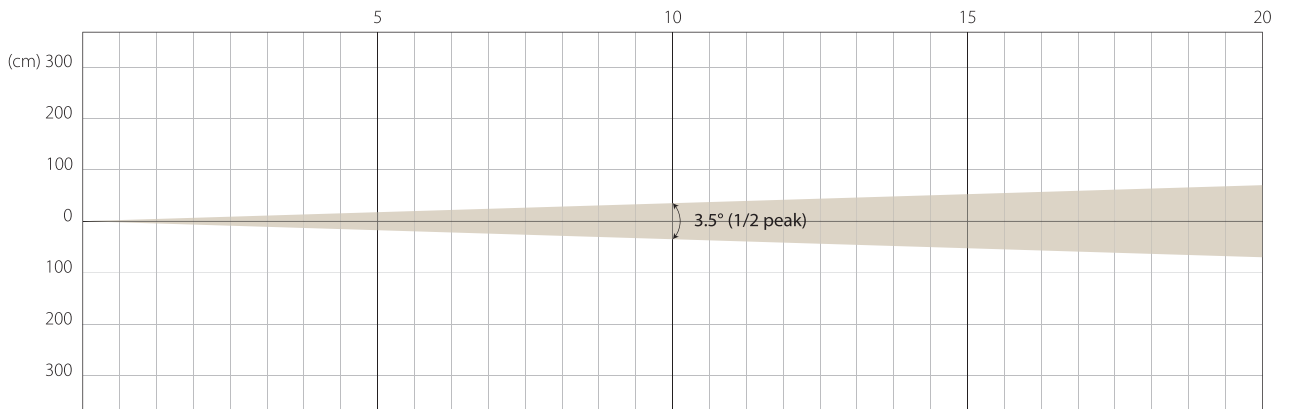

INTENSITY

Distance (m)	5		10		15		20	
	lux	diameter	lux	diameter	lux	diameter	lux	diameter
Red	3678	0.35	920	0.7	409	1.05	230	1.4
Green	8617	"	2154	"	957	"	539	"
Blue	1862	"	466	"	207	"	116	"
Lime	10520	"	2630	"	1169	"	657	"
RGB-L	21111	"	5277	"	2346	"	1320	"

MAX ZOOM

BEAM OPENING

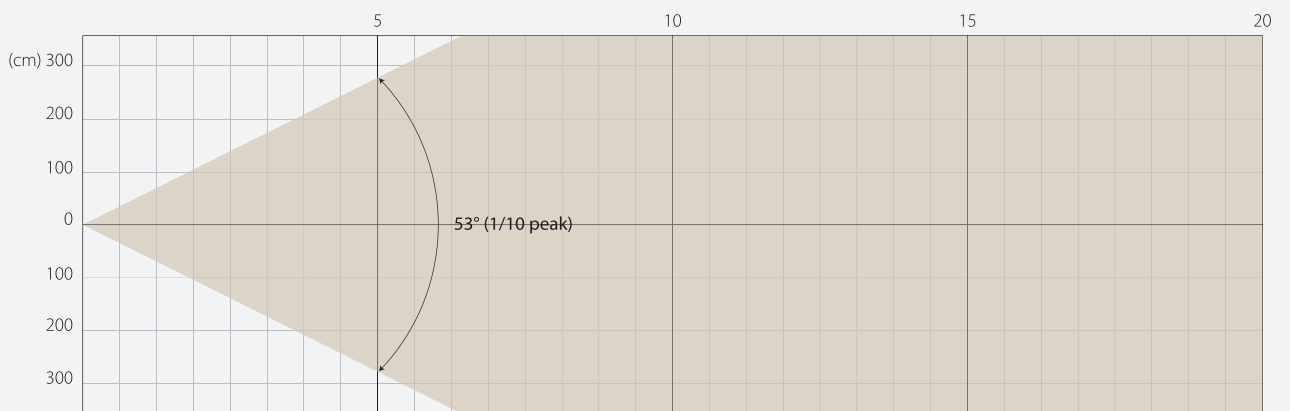

INTENSITY

Distance (m)	5		10		15		20	
	lux	diameter	lux	diameter	lux	diameter	lux	diameter
Red	82	5,54	20	11,09	9	16,63	5	22,17
Green	169	"	42	"	19	"	11	"
Blue	37	"	9	"	4	"	2	"
Lime	207	"	51	"	23	"	13	"
RGB-L	422	"	105	"	47	"	26	"

COLOUR PARAMETERS

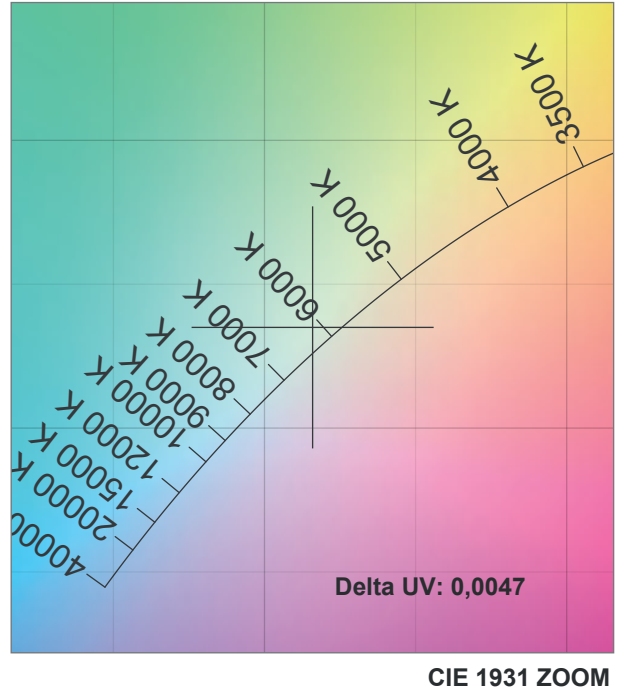
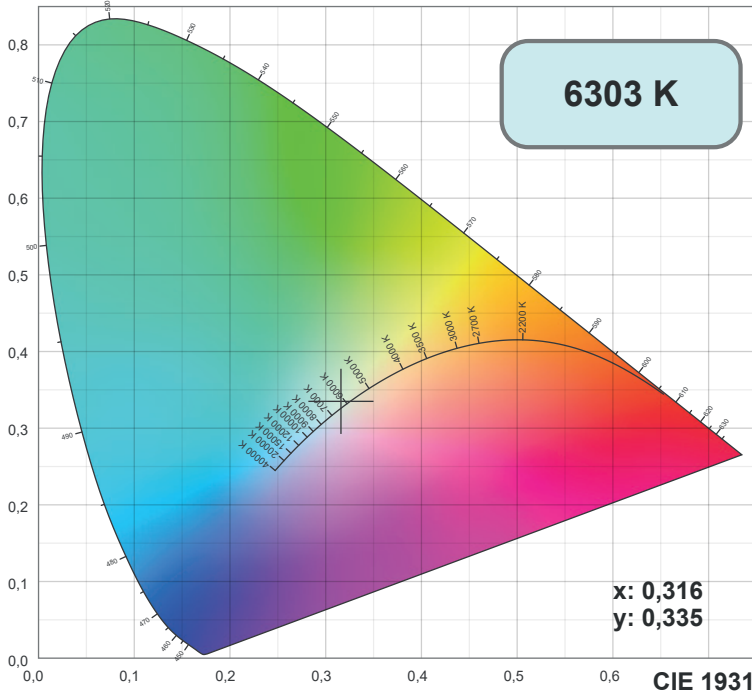

TM30: 82,8

CRI: 77,7 (R1-R8)

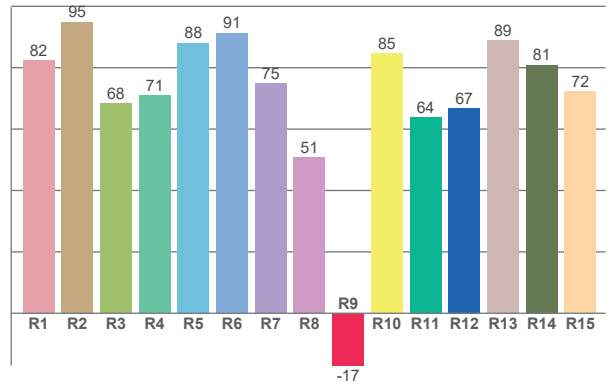
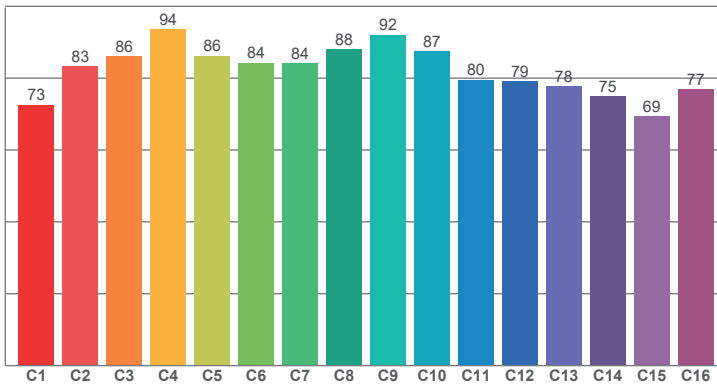

CRI R values, only R1-R8 are used to calculate final CRI value

R1	R2	R3	R4	R5	R6	R7	R8	R9	R10	R11	R12	R13	R14	R15
82,46	94,92	68,41	70,92	88,05	91,38	74,91	50,80	-17,06	84,70	63,90	66,80	88,92	80,94	72,24

TM30 C values, 16 binned values out of total of 99 C values

C1	C2	C3	C4	C5	C6	C7	C8	C9	C10	C11	C12	C13	C14	C15	C16
72,63	83,33	86,02	93,56	86,17	84,23	84,13	88,01	92,07	87,49	79,53	79,12	77,79	74,98	69,34	76,86

CQS Q values

Q1	Q2	Q3	Q4	Q5	Q6	Q7	Q8	Q9	Q10	Q11	Q12	Q13	Q14	Q15
83,59	93,85	82,44	94,19	89,49	85,09	93,23	88,57	81,18	91,97	92,07	82,25	77,78	91,74	90,04



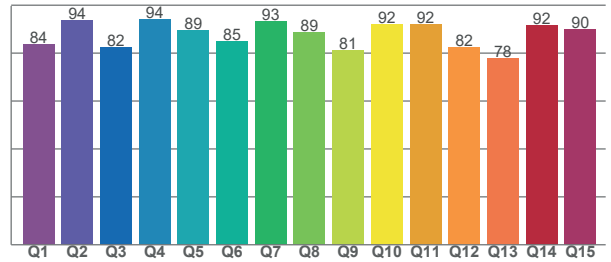







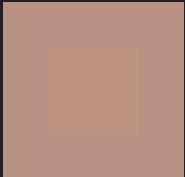

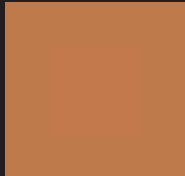

CQS: 86,8

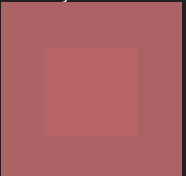
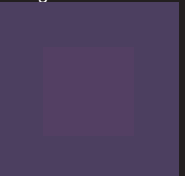

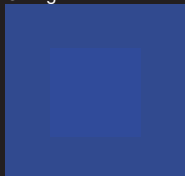
Color parameters

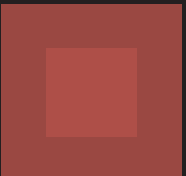
CCT	CRI	CRI R9	TM30 Rf	TM30 Rg	CQS	x	y	u	v	Duv
6303 K	77,7	-17,1	82,8	112,3	86,8	0,3	0,3	0,2	0,3	0,0014

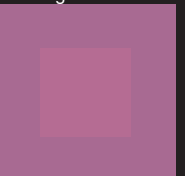
TLCI-66

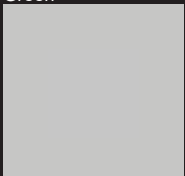
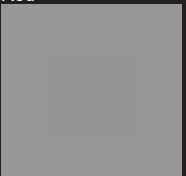
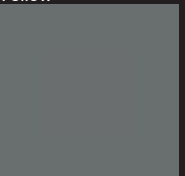
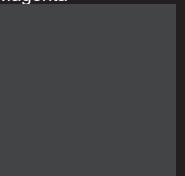
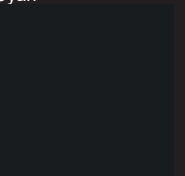
					
Dark skin	Light skin	Blue sky	Foliage	Blue flower	Bluis green
					
Orange	Purplish blue	Moderate red	Purple	Yellow green	Orange yellow
					
Blue	Green	Red	Yellow	Magenta	Cyan
					
White 90.01%	Neutral 8, 59.1%	Neutral 6.5, 36.2%	Neutral 5, 19.77%	Neutral 3.5, 9%	Black 3.13%

⚠️ DISCLAIMER

Errors and omissions for all information given in this specification sheet are possible. All information is subject to change without prior notice.